

# 45mm宽三节钢珠滑轨

## 45mm Full extension ball bearing slide

### YA4501



#### 基本参数 Basic Parameter

产品材质: 冷轧板  
 材料厚度: 1.0x1.0x1.2mm, 1.2x1.2x1.5mm (可选)  
 表面处理: 镀锌, 电泳黑  
 额定负重: 30-45KGS (450mm标准长度)  
 使用寿命: 过50000次, 通过SGS疲劳测试  
 尺寸范围: 250-600mm, 也可根据要求定制  
 安装方式: 侧部安装, 螺丝固定  
 产品特点: 配备高精度的生产线和检测仪器使产品超静音、顺滑

Product Material: Cold-rolled steel  
 Material Thickness: 1.0x1.0x1.2mm, 1.2x1.2x1.5mm available  
 Finish: Zinc plating, Electrophoresis black  
 Load rating: 30-45 KGS (450mm as standard)  
 Cycling: 50,000 times, pass the SGS fatigue test  
 Size range: 10" / 250mm - 24" / 600mm, customized is available  
 Installation: side mounting with screws  
 Product feature: Equipped with high precision production line and testing instrument products ultra-quiet, smooth

#### 安装孔位图 Hole Pattern For Installation

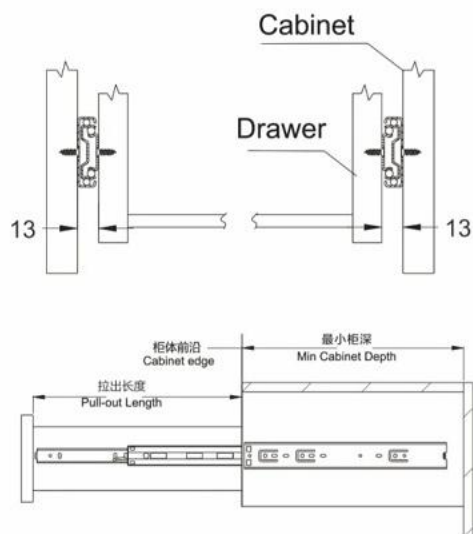

#### 产品规格 Product specifications

订货号 Item No.	滑轨长度 Slide Length	抽屉长度 Drawer Length	最小柜深 Min Cabinet Depth	包装单位 (套/箱) Packing Unit (set/box)
YA4501-10	10"/250mm	250mm	254mm	10
YA4501-12	12"/300mm	300mm	304mm	10
YA4501-14	14"/350mm	350mm	354mm	10
YA4501-16	16"/400mm	400mm	404mm	10
YA4501-18	18"/450mm	450mm	454mm	10
YA4501-20	20"/500mm	500mm	504mm	10
YA4501-22	22"/550mm	550mm	554mm	10
YA4501-24	24"/600mm	600mm	604mm	10
YA4501-26	26"/650mm	650mm	654mm	10
YA4501-28	28"/700mm	700mm	704mm	10

#### 滑动轨安装尺寸 Installation Dimensions

