

# 37mm宽三节钢珠滑轨

## 37mm Full extension ball bearing slide

### YA3701



#### 基本参数 Basic Parameter

产品材质: 冷轧板  
 材料厚度: 1.2x1.0x1.2mm  
 表面处理: 镀锌, 电泳黑  
 额定负重: 30KGS (450mm标准长度)  
 使用寿命: 过50000次, 通过SGS疲劳测试  
 尺寸范围: 150-650mm, 也可根据要求定制  
 安装方式: 侧部安装, 螺丝固定  
 产品特点: 配备高精度的生产线和检测仪器使产品超静音、顺滑

Product Material: Cold-rolled steel  
 Material Thickness: 1.2x1.0x1.2mm  
 Finish: Zinc plating, Electrophoresis black  
 Load rating: 30 KGS (450mm as standard)  
 Cycling: 50,000 times, pass the SGS fatigue test  
 Size range: 150mm - 650mm, customized is available  
 Installation: side mounting with screws  
 Product feature: Equipped with high precision production line and testing instrument products ultra-quiet, smooth

#### 安装孔位图 Hole Pattern For Installation

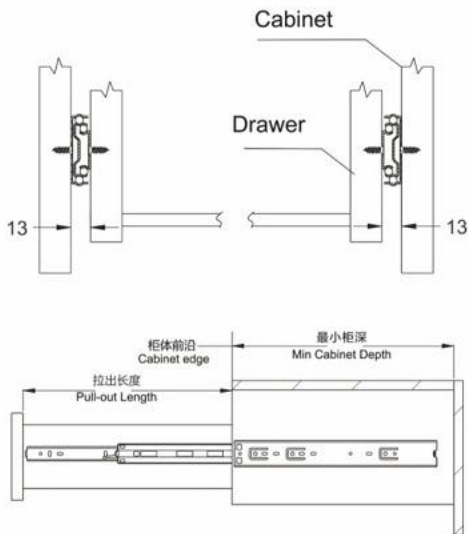

#### 产品规格 Product specifications

订货号 Item No.	滑轨长度 Slide Length	抽屉长度 Drawer Length	最小柜深 Min Cabinet Depth	包装单位 (套/箱) Packing Unit (set/box)
YA3701-6	6"/150mm	150mm	154mm	20
YA3701-8	8"/200mm	200mm	204mm	20
YA3701-10	10"/250mm	250mm	254mm	20
YA3701-12	12"/300mm	300mm	304mm	20
YA3701-14	14"/350mm	350mm	354mm	20
YA3701-16	16"/400mm	400mm	404mm	20
YA3701-18	18"/450mm	450mm	454mm	20
YA3701-20	20"/500mm	500mm	504mm	20
YA3701-22	22"/550mm	550mm	554mm	20
YA3701-24	24"/600mm	600mm	604mm	20
YA3701-26	26"/650mm	650mm	654mm	20

#### 滑动轨安装尺寸 Installation Dimensions

