

35mm宽三节钢珠滑轨

35mm Full extension ball bearing slide

YA3501



基本参数 Basic Parameter

产品材质: 冷轧板
 材料厚度: 1.0x1.0x1.2mm
 表面处理: 镀锌, 电泳黑
 额定负重: 30KGS (450mm标准长度)
 使用寿命: 过50000次, 通过SGS疲劳测试
 尺寸范围: 150-650mm, 也可根据要求定制
 安装方式: 侧部安装, 螺丝固定
 产品特点: 配备高精度的生产线和检测仪器使产品超静音、顺滑

Product Material: Cold-rolled steel
 Material Thickness: 1.0x1.0x1.2mm
 Finish: Zinc plating, Electrophoresis black
 Load rating: 30 KGS (450mm as standard)
 Cycling: 50,000 times, pass the SGS fatigue test
 Size range: 150mm - 650mm, customized is available
 Installation: side mounting with screws
 Product feature: Equipped with high precision production line and testing instrument products ultra-quiet, smooth

安装孔位图 Hole Pattern For Installation

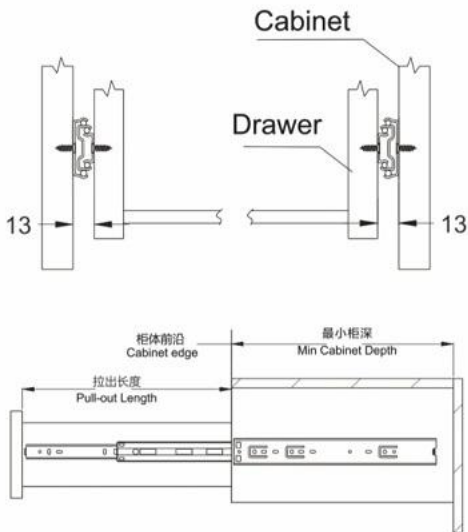

产品规格 Product specifications

订货号 Item No.	滑轨长度 Slide Length	抽屉长度 Drawer Length	最小柜深 Min Cabinet Depth	包装单位 (套/箱) Packing Unit (set/box)
YA3501-6	6"/150mm	150mm	154mm	20
YA3501-8	8"/200mm	200mm	204mm	20
YA3501-10	10"/250mm	250mm	254mm	20
YA3501-12	12"/300mm	300mm	304mm	20
YA3501-14	14"/350mm	350mm	354mm	20
YA3501-16	16"/400mm	400mm	404mm	20
YA3501-18	18"/450mm	450mm	454mm	20
YA3501-20	20"/500mm	500mm	504mm	20
YA3501-22	22"/550mm	550mm	554mm	20
YA3501-24	24"/600mm	600mm	604mm	20
YA3501-26	26"/650mm	650mm	654mm	20

滑动轨安装尺寸 Installation Dimensions

